



PHOTONIA

outdoor wall light, A60, IP55, round, anthracite, transparent glass, max. 60W

Article number	232045
Feed-in capability	No
Lampholder / Socket	E27
Number of light sources	1
Lamp included	No
Width	14.6 cm
Height	25 cm
Depth	20 cm
Net weight	1.395 kg
Gross weight	1.834 kg
Voltage	220-240V ~50/60Hz
Max. wattage	60 Watt
Protection class	I
IP-rating	IP 55
Energy efficiency class	A++
Catalogue page	BIG WHITE 2018: 773
Light distribution type 1	direct - indirect
Lamp	A60
Colour	anthracite
Material	Aluminium/glass
Way of mounting	Surface mounted / Wall mounted

The PHOTONIA wall light is made from aluminium and transparent glass, which completely encloses the lamp. Thanks to the position of the built-in sockets, the installed luminaire produces a homogeneous cone of light. With protection class IP55, it is suitable for outdoor use. The electrical connection is made directly to the 230V mains supply. This luminaire is suitable for lamps of energy classes: E - A+

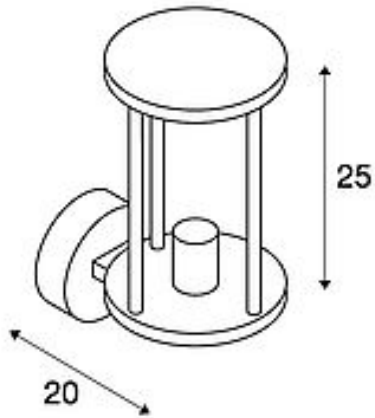

Notes
