

Technical Data Sheet

CODE 11149

MF 120/5" T HCS LL

Wall axial fans



Certifications



IMQ Performance



TECHNICAL AND PERFORMANCE DATA

Absorbed Current max (A)	0,12	Weight (Kg)	0,62
Absorbed Power max (W)	20	Delivery max (l/s)	49
Frequency (Hz)	50	Delivery max (m ³ /h)	175
Insulation Class	II°	Pressure max (mmH2O)	5
IP	X4	Pressure max (Pa)	49
Max ambient temperature for continuous operation (°C)	50	RPM	2150
Voltage (V)	220-240	Sound Pressure level Lp [dB (A)] 3m	34,4

DIMENSIONS

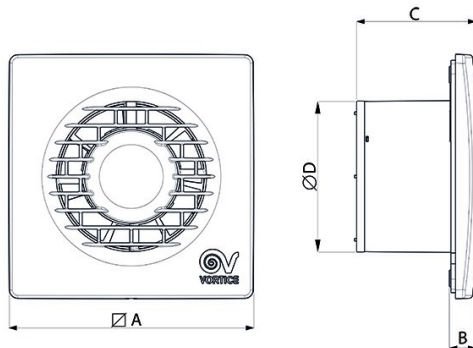

Etichetta Energetica	N0
Size A (mm)	179
Size B (mm)	17
Size C (mm)	89
Size D (mm)	119

PER INFORMAZIONI:

Servizio al Cliente: tel +39 02 90699395 premendo 1 dopo messaggio registrato (consulenza su prodotti e impianti)

Pre & Post Vendita: fax +39 02 90699302

Email prevendita: prevendita@vortice-italy.com

Technical Data Sheet

CODE 11149

MF 120/5" T HCS LL

Wall axial fans



DESCRIPTION

- Material: UV resistant plastic (prevents ageing caused by exposure to sunlight).
- Nominal diameter 120 mm.
- Motor protected against thermal overload, with shaft turning in ball bearings, coupled to screw type thermoplastic impeller with wing profile blades.
- Maximum air flow: 175 m³/h.
- Electronic pcb with humidistat function piloted by RH sensor (4 preset thresholds: 60%, 70%, 80%, 90%, selectable during installation), designed to switch on the fan automatically. The pcb incorporates an electronic timer that shuts off the motor automatically when relative humidity returns below the threshold value. The timer setting is selectable during installation in the range 3'-20' (default setting 3').
- Non-return damper fitted to outlet port.
- IMQ SAFETY and IMQ PERFORMANCE certifications.
- Vortice speed controller.

CURVES

□

ACCESSORIES

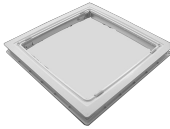

SF 120

Code 22163

PER INFORMAZIONI:

Servizio al Cliente: tel +39 02 90699395 premendo 1 dopo messaggio registrato (consulenza su prodotti e impianti)

Pre & Post Vendita: fax +39 02 90699302

Email prevendita: prevendita@vortice-italy.com